

1DSEC2

DESCRIZIONE Dissipatore ecologico
DESCRIPTION Food waste disposer

PESO LORDO 7.8 kg
GROSS WEIGHT

DIMENSIONI IMBALLO 405x225x22.5 mm
PACKAGING DIMENSIONS



Per tutti i lavelli e vasche quadre con pilettone 3"1/2
 For all sinks and square bowls with 3.5 basket strainer waste

- Componenti trituranti in acciaio inox (*stainless steel shredder components*)
- Camera di triturazione e scarico materiale anticorrosione (*shredding chamber and drain in anti-corrosive material*)
- Piletta in nylon e fibra di vetro sistema singolo di triturazione, motore standard (*nylon and fibre glass basket*)
- Alimentazione continua (*Powered continuously*)
- Motore 200-240V/50Hz (*Engine*)
- Isolamento antirumore (*Sound-proofing*)
- Classe 1 (*Energy rating 1*)
- Motore lubrificante permanente (*Engine with permanent lubricant*)
- Reset manuale/protezione da sovraccarico (*Manual reset/protection against overload*)
- Dispositivo avviamento pneumatico in materiale plastico in dotazione (*Plastic pneumatic starter included*)
- Potenza: 1/2 HP, 380 W (*Power*)
- Spessore massimo vasca 15 (mm)

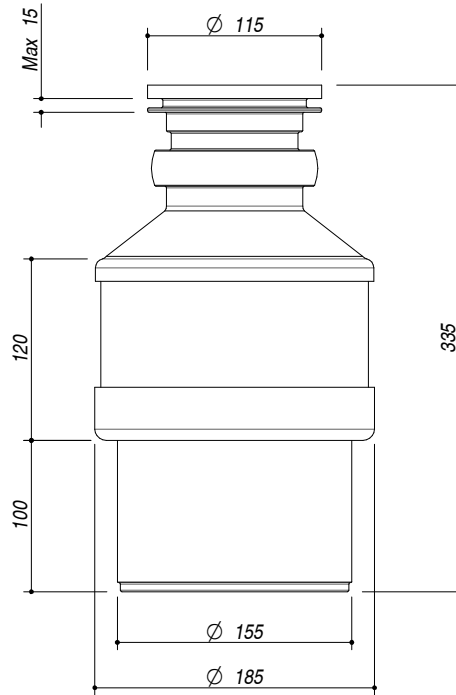
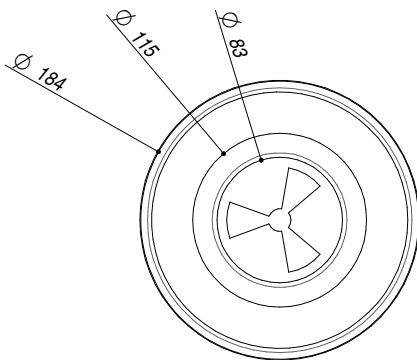

SCALA DISEGNO 1:5
DRAWING SCALE



TUTTE LE MISURE IN mm
ALL MEASURES IN mm

TOLLERANZA LINEARE: ± 0.5 mm
LINEAR TOLERANCE

TOLLERANZA ANGOLARE: ± 0.2 °
ANGULAR TOLERANCE